

OUTPUT Connections

There are two VIDEO OUT connectors. Please connect each connector with a cable to a device, e.g. a monitor.

There are two Audio OUT connectors. Please connect each connector with a cable to a device, e.g. a monitor or a speaker.

There are two ALARM OUT connectors. Please link the N.C. N.O. connect from each of the ALARM OUT connectors to other further application devices.

Distributor/Retailer



Copyright (c) 2006.
All Rights Reserved.
Foresight CCTV, Inc.
Email: info@foresight-cctv.com
Made in Taiwan



VDS2510 Installation Manual

Viewer
2510-L (Local Unit)



Sender
2510-R (Remote Unit)

Content

Introduction.....2
 Features.....2
 Packing Checklist.....2
 Certificate.....2
 Patents.....2
 Limited Warranty.....2
 Specification of VDS2510-R Sender.....3
 Specification of VDS2510-L Viewer.....3
 Functions of Remote Unit (VDS2510-R Sender).....4
 Functions of Local Unit (VDS2510-L Viewer).....5
 Installation of Remote Unit and Local Unit.....6
 Making Connection.....8
 Installation Notice.....8
 Connecting Sender Unit.....9
 Connecting Viewer Unit.....11

Introduction

The VDS2510 series is a transmission system for sending two video, two audio, two alarm signals and DC power through one coaxial cable. The system can transmit signals and 12VDC power up to 800 meters. If a camera is powered at the remote end, without DC power supplying from Viewer, the transmission distance of the VDS2510 can reach 1,000 meters.

Features

- & One cable transmits all signals and DC power.
- & Universal Voltage Input (85V~265V).
- & Up to 800 meters transmission range while sending DC power from the Viewer unit; up to 1,000 meters transmission range when cameras have another power source.
- & Real time analog video signals for color and B/W (50fps/60fps), better than 480TVL resolution.
- & Built-in electrical transient voltage suppressor (TVS) protection, gas tube arrester protection and lightning protection
- & Inter-carrier technology eliminates signal interference.
- & Accept both N.C. or N.O. alarm connection, or mix of N.C. and N.O. In Term mode.

Packing Checklist

Carefully unpack the VDS2510 and check that the following items are included:

- & VDS2510-R Sender (Remote Unit)
- & VDS2510-L Viewer (Local Unit)
- & Power supply (AC to DC power adapter) and power cord
- & Four mounting brackets and four screws
- & Two 1,000 ohms terminators for alarm mode use in Alarm Input side.
- & Installation Manual

Contact your dealer immediately if any of the above items appears damaged or the unit does not work.

Certificate

This equipment has been tested and found to comply with the Part 15 rules of the US FCC Regulation, and gets CE approved.

Patents

Patents covering the design, operation, techniques, and unique features of the Single-cable transmission device of a surveillance system include: U.S. Patent #US 6,369,699 B1 April 9, 2002; Taiwan Patent #201389 September 3 2004; Europe Patent #EP 1134909 A1 September 19, 2001. Other Patents are pending.

Limited Warranty

Foresight grants a warranty for this product for 18 months. Please offer the purchase date and the serial Number of Bar-Code on the back of the product to your distributor or retailer as proof for this purpose. During the warranty period, in case of defected in material or workmanship, the defective unit will be repaired or replaced according to the assessment of Foresight. However, this warranty does not cover damages caused by improper use or from unauthorized modifications by third parties.

Connecting Viewer unit

The following illustration shows the connections for the Viewer unit:

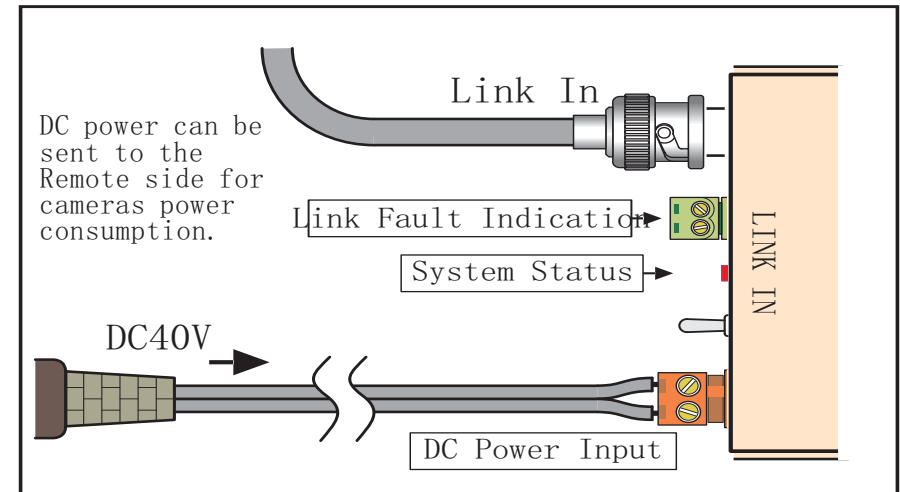

LINK IN Connections

Connect the other end of the coaxial cable which is connected to the LINK OUT side of the Sender unit to the LINK IN side of the Viewer unit.

Connect a wire from the +12V pin and Out of the LINK FAULT PTB connector to a buzzer or an indicator wherever you want.

Plug the power cord on and connect the AC to DC power adapter to the DC POWER IN connector in the LINK IN side of the Viewer unit.

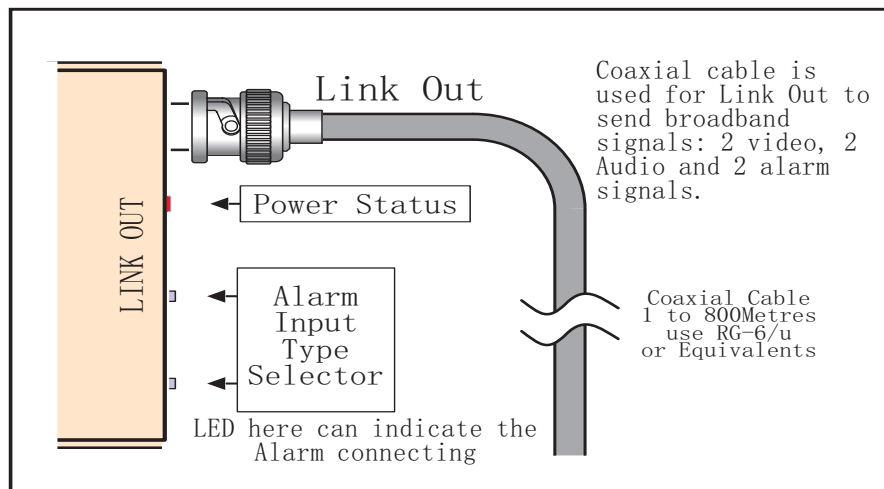

LINK OUT Connection

Connect the LINK OUT of Sender unit with one end of a coaxial cable, and connect the other end of the coaxial cable to the LINKIN side of

Specification of VDS2510-R Sender

To ensure smooth operation of VDS2510, the following minimum system and setup requirements should be met.

Electrical:

All video, Audio and Alarm have two inputs
 Video Input Signal: 1.0Vpp, 75 ohms
 Bandwidth of Video Signal: 5.5MHz typ.
 Audio Input Signal: 3.0Vpp, 100K ohms, max
 Alarm Input type: N.C./N.O./Terminal 1,000 ohms
 Power Output: DC12V, 1.0 A(2 cameras in total), max.

Connection: (PTB= Plugable Terminal Block)

Video Input: BNC Socket X 2
 Audio Input, Alarm Input and DC Out: 5 Pin PTB X 2, 3.5mm Pitch
 Link Out: BNC Socket

Specification of VDS2510-L Viewer

Electrical:

All video, Audio and Alarm have two outputs
 Video Output Signal: 1.0Vpp, 75 ohms
 Bandwidth of Video Signal: 5.5MHz typ.
 S/N ratio of Video Signal: 50dB typ.
 Gain of Audio signal Output: 0dB \pm 3dB, 600 ohms / internal impedance
 Bandwidth of Audio Signal: 50Hz to 10KHz \pm 3dB
 S/N Ratio of Audio Signal: 46dB under 1.0Vpp input at RU
 Alarm Output: N.C./N.O., Contact Rating 1A, 30VDC Dry contact
 DC Power Input: 40V
 Max. DC power Output: 38V, 1.6A, min.
 Link Fault Output : 0.15A, min.

Connection: (PTB= Plugable Terminal Block)

Link In: BNC Socket
 Link Fault: 2 Pin PTB, 3.5mm Pitch
 DC Power Input: 2 Pin PTB, 5.0mm Pitch
 Video Output: BNC Socket X 2
 Audio Output and Alarm Output: 5 Pin PTB X 2, 3.5mm Pitch

Functions of Remote Unit

VDS2510-R Sender

INPUT side

VIDEO IN:

to receive a video signal from video source, eg. a camera.

AUDIO IN:

to receive an audio signal from an audio source, eg. a microphone.

ALARM IN:

to receive alarm connection from devices like sensors or infra-red detective devices. Both N.O. and N.C. are acceptable, even at the same time (under the TERM).

DC OUT:

to send 12VDC power to cameras.

LINK OUT Side

LINK OUT with DC IN:

to send out two video, two audio, two alarm signals to the Viewer unit and to receive DC power from the Viewer unit.

POWER STATUS LED:

to indicate the power supplying condition. When LED is red, it implies the power supplying to camera is stand-by or not been used. When LED is green, it means the power is loaded well to the camera. When LED is Yellow, it means the DC power is low. Please check if the cable used is over length limitation or the DC consumption of the two cameras in total is more than 1.0A (note1). When LED is flashing, it implies the power supply might be failed due to the power is too low to offer any function.

ALARM

LED:

to indicate the Alarm Input and Alarm Output are both well working.

CONNECTION INPUT TYPE:

to let users to select which alarm connection type to apply: N.C. or N.O. or TERM (mixed with N.O. and N.C.)

Note 1. The 1.0A is based on the condition of less than 600M distances and 5C-2V coaxial cable used.

Please refer to How to Use Alarm manual enclosed.

Connecting Sender unit

The following illustration shows the connections for the Sender

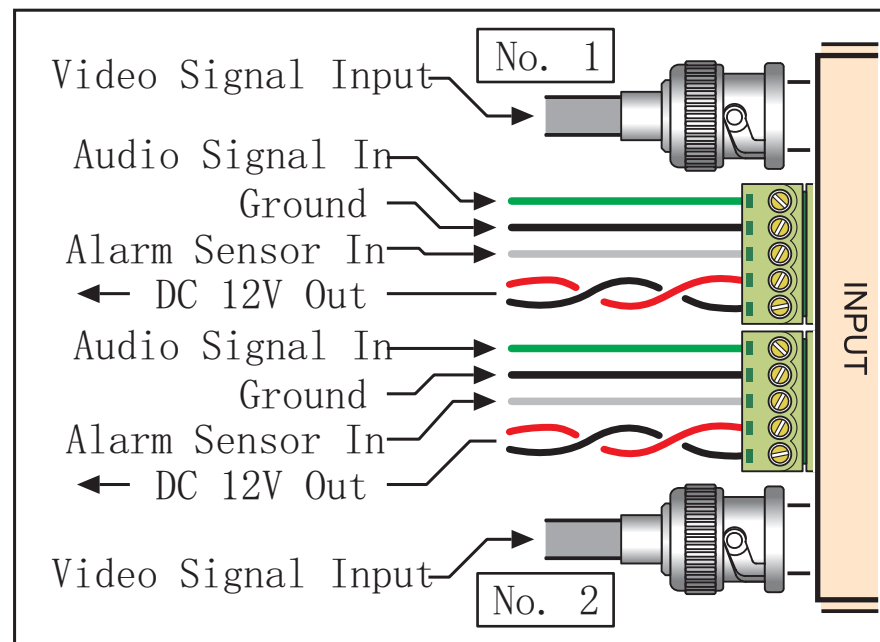

INPUT Connection

There are two VIDEO IN connectors. Please connect each VIDEO IN connector with one end of a cable carrying video signal from the video source.

There are two AUDIO IN connectors. Please connect each AUDIO IN connector with one end of a cable carrying audio signal from the audio source.

There are two ALARM IN connectors. Please connect each PTB connector in ALARM IN with a wire with the N.O./N.C. connection from sensors. Please refer to How to Use Alarm manual to improve security and flexibility of alarm connection.

There are two DC OUT connectors. Please connect each DC OUT connectors with the power cord (DC 12V) to the video source, e.g. a camera.

Making Connection

The following illustration gives an overview of the Sender unit and the Viewer unit connections.

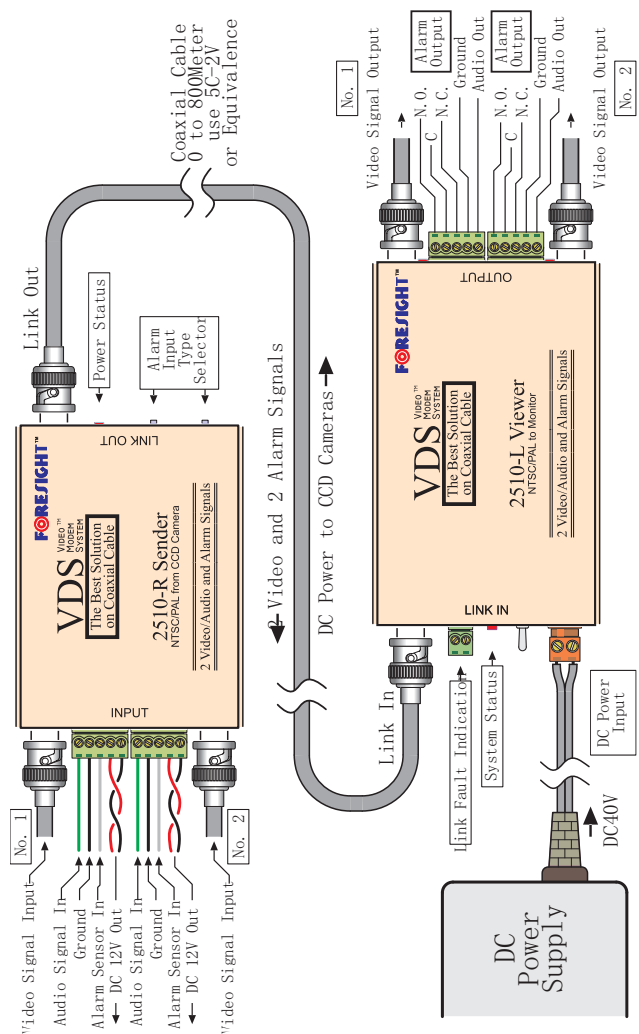

Installation Notice

When setting up the VDS2510 Sender unit and Viewer unit, be sure to note the following points:

Both units should be fixed securely to a permanent object such as a wall or a pillar.

Avoid locations with extreme vibrations or dust.

Avoid locations with dampness or extreme heat.

Functions of Local Unit

VDS2510-L Viewer

LINK IN side

LINK IN with DC OUT:

to receive in two video, two audio, and two alarm signals from the Sender unit and also to send DC power out to the Sender unit.

LINK FAULT:

to warn users if the cable between Sender unit and Viewer unit is disconnected. To allow users to send the warning signal to an extra warning device, e.g. buzzer, relay or light bulb and everywhere users prefer.

SYSTEM STATUS LED:

When users turn off the system, LED will be red. When users turn on the system, LED will be yellow at the first 5 seconds for initial, and then become green. The LED will keep green, when the system is on.

ON/OFF:

to turn on or turn off the system

DC POWER IN:

to input the power from the power supply.

OUTPUT side

VIDEO OUT:

to send the video signals out to a device, e.g. A monitor or DVR

AUDIO OUT:

to send out the audio signals to a device, e.g. monitor or loudspeaker amplifier. The audio signal level output from the AUDIO OUT is exactly the same as what the AUDIO IN received at Sender Unit.

ALARM OUT:

to send the alarm connection out for a further application.

LED:

To indicate the alarm function is operating.

Installation of Remote and Local Units

The VDS2510 units can both be fixed to a wall or desktop with the supplied mounting brackets. The mounting brackets can be fixed onto the rear, top, or bottom of either unit.

Attaching the Mounting Brackets

Attach the mounting brackets to either the Sender unit or the viewer unit as shown below:

1. Align the mounting bracket with the mounting track on the rear of the unit as shown here:

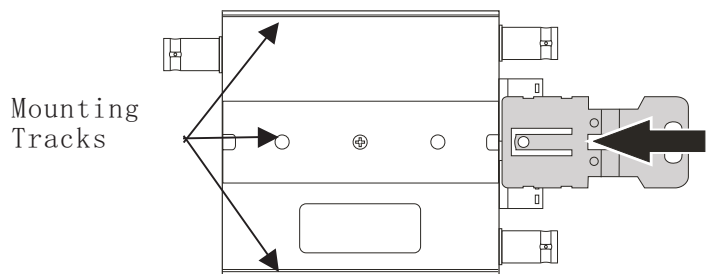

2. Slide the bracket in the direction of the arrow until the white nub clicks into place as shown below:

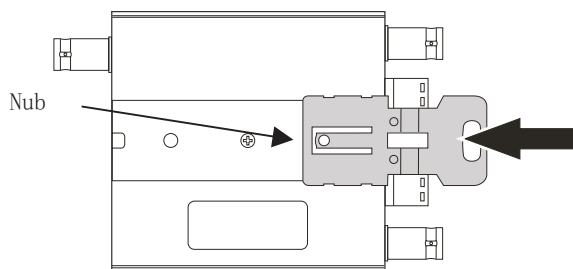

3. Repeat the above steps on another side of the unit to attach the second bracket.

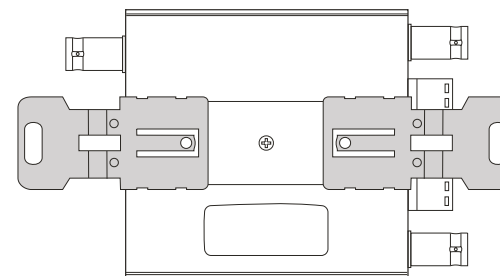

4. Fix the unit in the desired location with two screws.

Removing the Mounting Brackets

Remove the mounting as shown below:

1. Use a flat-tipped screwdriver to lift the white nub as shown below:

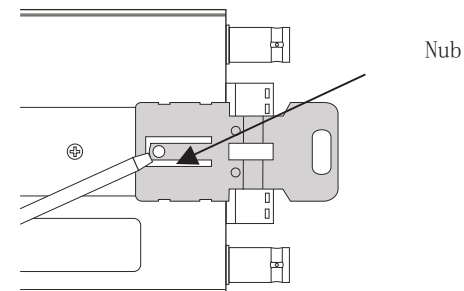

2. While lifting the nub, slide the bracket out in the direction of the arrow as shown below:

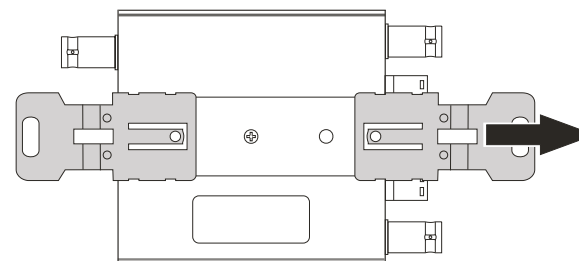

3. Repeat the above steps to remove the second bracket.